

Schnitt A-A

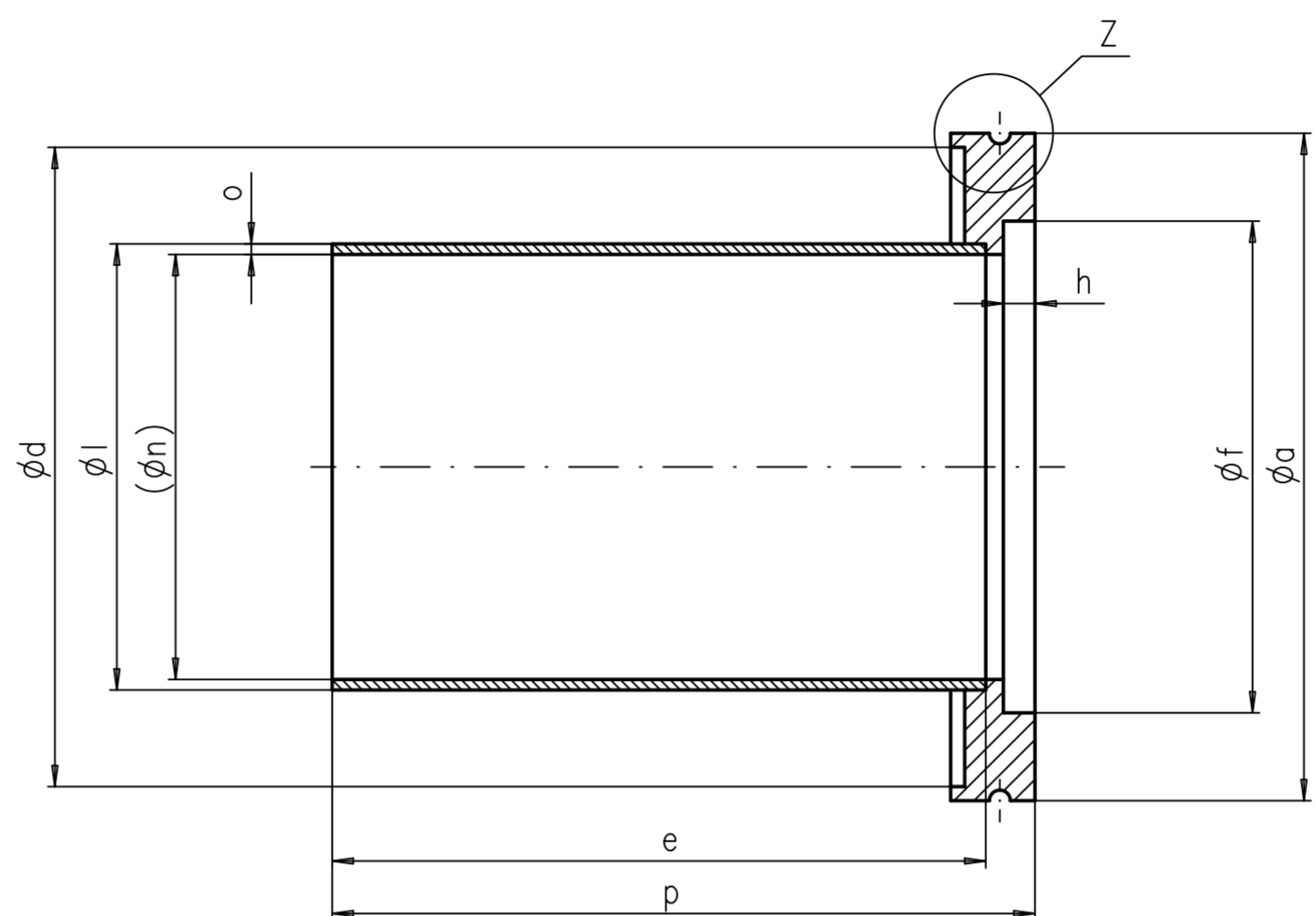

Einzelheit Z 5:1

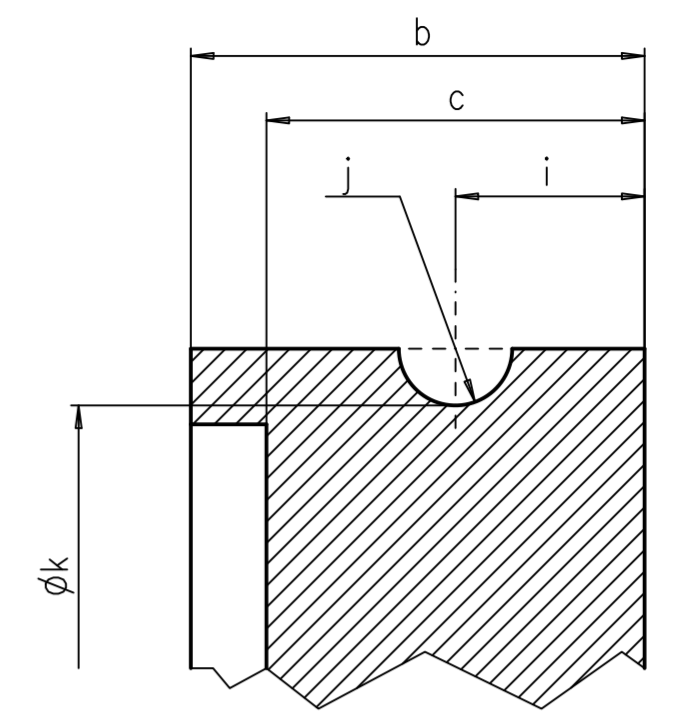

DN	a	b	c	d	e	f	g	h	i	j	k	l	m	(n)	o	p
63	95	12	10	91	93	70	---	4,5	5	R1,5	92	63,5	---	60,5	1,5	100
63	95	12	10	91	93	70	---	4,5	5	R1,5	92	70	---	66	2	100
63	95	12	10	91	93	70	---	4,5	5	R1,5	92	76,1	---	72,1	2	100
80	110	12	10	106	93	83	---	4,5	5	R1,5	107	76,1	---	72,1	2	100
80	110	12	10	106	93	83	---	4,5	5	R1,5	107	85	---	81	2	100
80	110	12	10	106	93	83	---	4,5	5	R1,5	107	89,1	---	85,1	2	100
100	130	12	10	126	93	102	---	4,5	5	R1,5	127	89,1	---	85,1	2	100
100	130	12	10	126	93	102	---	4,5	5	R1,5	127	104	---	100	2	100
100	130	12	10	126	93	102	---	4,5	5	R1,5	127	108	---	102	3	100
160	180	12	10	176	93	153	---	4,5	5	R2,5	175	154	---	150	2	100
160	180	12	10	176	93	153	---	4,5	5	R2,5	175	159	---	155	2	100
200	240	12	10	236	93	213	---	4,5	5	R2,5	235	204	---	200	2	100
200	240	12	10	236	93	213	---	4,5	5	R2,5	235	219,1	---	215,1	2	100
250	290	12	10	286	93	261	---	4,5	5	R2,5	285	254	---	250	2	100
250	290	12	10	286	93	261	---	4,5	5	R2,5	285	273	---	267	3	100
250	290	12	10	286	293	261	---	4,5	5	R2,5	285	273	---	267	3	300
250	290	12	10	286	393	261	---	4,5	5	R2,5	285	273	---	267	3	400
320	370	17	15	366	93	318	---	4,5	7,5	R2,5	365	324	---	318	3	100
320	370	17	15	366	146	318	---	4,5	7,5	R2,5	365	324	---	318	3	153
400	450	17	15	446	93	400	---	4,5	7,5	R4	442	406	---	400	3	100

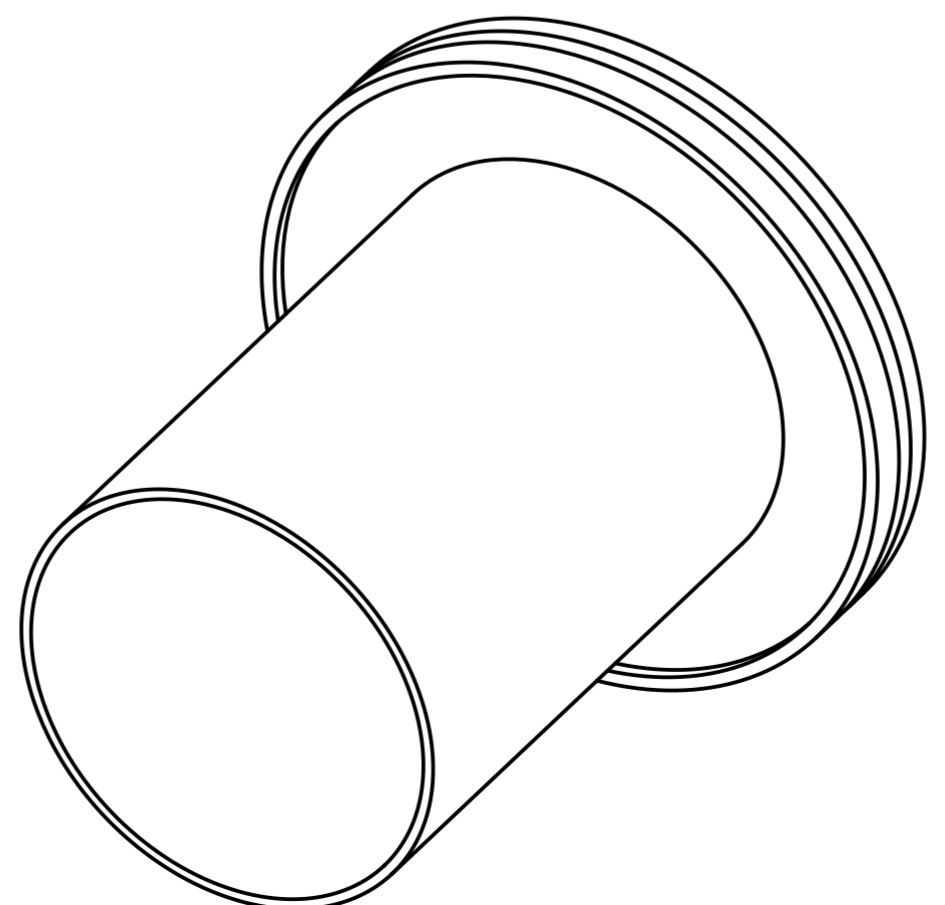
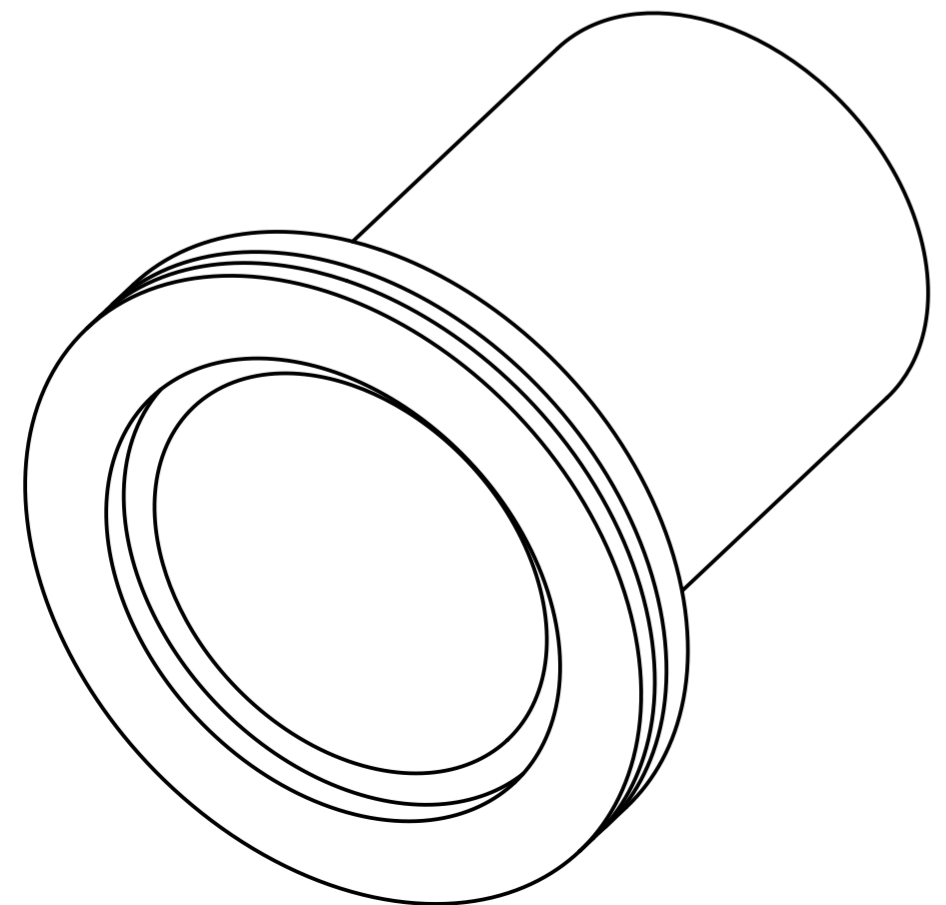

Maße entsprechen DIN 28404

		<small>Weitergabe sowie Vervielfältigung dieses Dokuments, Verwertung und Mitteilung seines Inhalts sind verboten, soweit nicht ausdrücklich gestattet. Zuwiderhandlungen verpflichten zu Schadensersatz. Alle Rechte für den Fall der Patent-, Gebrauchsmuster- oder Geschmacks-mustereintragung vorbehalten.</small>	
		<small>Moßstab</small> 1:1(5:1)	
<small>Datum</small> 10.02.16		<small>Name</small> MH	
<small>Gepr.</small> 10.02.16		<small>Dirk Neubauer</small>	
<small>Frei.</small> 10.02.16		<small>Dirk Neubauer</small>	
<small>Zeichnungsname</small> Anschweißflansche m. Rohransatz ISO-K		<small>Zeichnungsnummer</small> 000003-00-00-1	